

IV

Designing Helical Piles per the IBC

4.1 Introduction

Helical piles and anchors have been used in construction applications for more than 175 years. However, there was not a uniform standard of testing helical systems until the International Code Council (ICC) approved the Acceptance Criteria for Helical Foundation Systems (AC358) in June 2007. Before an acceptance criterion for helical foundation systems was adopted by ICC, the foundation industry relied on legacy evaluation reports. Only a few helical manufacturers held Legacy Reports including Ram Jack. Legacy Reports were published by older model building codes but recognized by ICC. Legacy Reports were valuable in providing the capacities of

helical foundation system components for engineers and building officials. However, Legacy Reports did not provide capacities of how the components functioned as a “System”.

AC358 recognizes four helical foundation applications: remedial repair (side load), direct load (new construction), floor slab and tieback anchors (tension). For each application, there are four structural elements that must be evaluated, bracket capacity and its connection to the structure (P1), shaft capacities with consideration to buckling and eccentricities (P2), helix plate capacity (P3) and soil interaction capacity (P4). Please reference Figures 4.1 and 4.2.

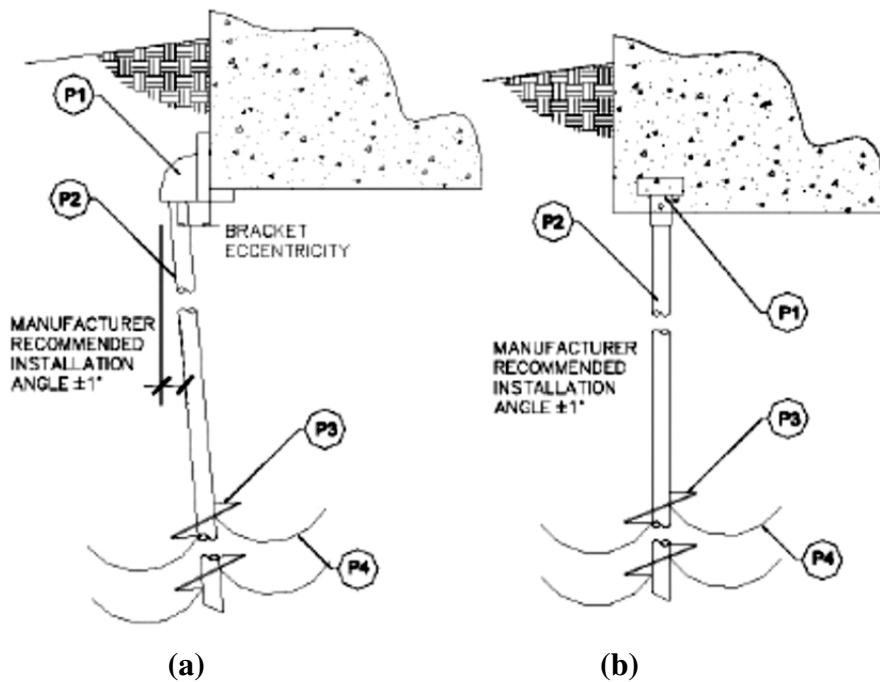

Figure 4.1: Helical Foundation Applications – (a) Remedial Repair and (b) Direct Load

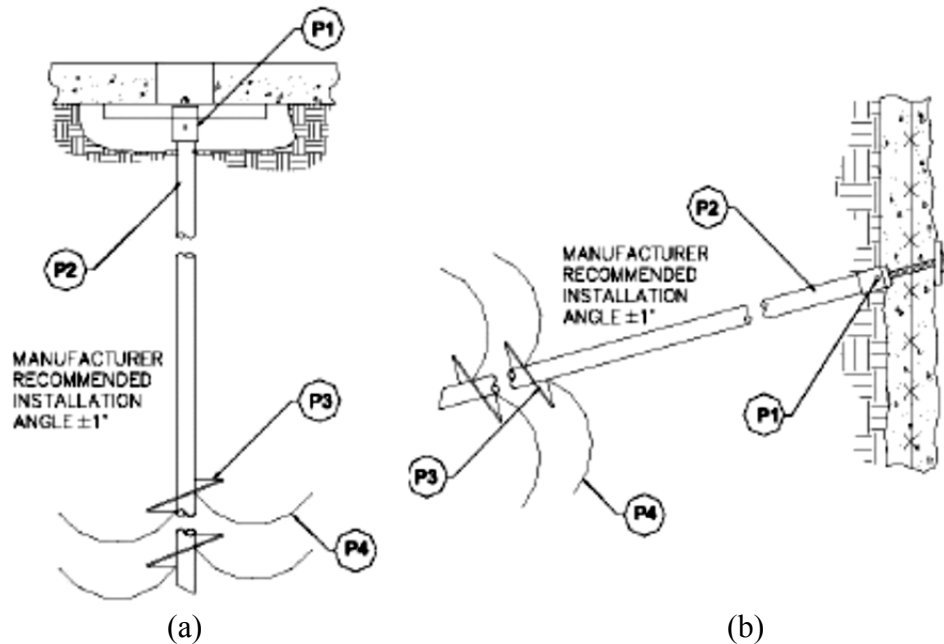

Figure 4.2: Helical Foundation Applications – (a) Floor Slab and (b) Tieback Anchor

Helical piles are important foundation innovations because of their versatility. Ram Jack was the first helical manufacturer to meet all the requirements of AC358 and receive their Evaluation Service Report (ESR-1854) on February 1st, 2011. Ram Jack is also the only helical manufacturer that currently has ICC recognized piles and brackets listed in their ESR report for all the helical foundation applications listed in AC358.

With the adoption of AC358, ICC also completely revised Chapter 18 ‘Soils and Foundations’ of the 2009 International Building Code (IBC) and added helical piles to the model code. The intent of this chapter is to aid foundation design engineers. This chapter specifically discusses how to design helical piles per the 2009 and 2012 IBC with excerpts and commentary applicable to helical piles. Most of the IBC section excerpts presented here are not new and exist in past IBC codes. This chapter also includes all the applicable code sections so

that the designer will have a better understanding of the design process of helical piles and the intent of the code.

SECTION 1802 - DEFINITIONS

Section 1802.1 defines a helical pile as:

Helical Pile: *Manufactured steel deep foundation element consisting of a central shaft and one or more helical bearing plates. A helical pile is installed by rotating it into the ground. Each helical bearing plate is formed into a screw thread with a uniform defined pitch.*

SECTION 1810 – DEEP FOUNDATIONS

Section 1810 includes all deep foundation elements specifically mentioned in the IBC. Excerpts pertaining to the design criterion of helical piles have been extracted from this section for review and discussion.

1810.1.3 Deep Foundation Elements Classified as Columns. *Deep foundation elements standing unbraced in air, water or fluid soils shall be classified as columns and designed as such in accordance with the provisions of this code from the top down to the point where adequate lateral support is provided in accordance with Section 1810.2.1.*

1810.2.1 Lateral Support. *Any soil other than fluid soil shall be deemed to afford sufficient lateral support to prevent buckling of deep foundation elements in accordance with accepted engineering practice and the applicable provisions of this code.*

Where deep foundation elements stand unbraced in air, water or fluid soils, it shall be permitted to consider them laterally supported at a point 5 feet (1542 mm) into stiff soil or 10 feet (3048 mm) into soft soil unless otherwise approved by the building official on the basis of a geotechnical investigation by a registered design professional.

Traditionally the IBC has used the section for lateral support to define the minimum unbraced length a deep foundation element must be designed for. The first paragraph of Section 1810.2.1 is new in reference to the previous International Building Codes and is somewhat contradictory to Section 1810.2.2 – Stability; which defines a laterally braced deep foundation element.

Most engineers interpret the code to mean that deep foundation elements that are not clearly defined as a laterally braced pier or pile in accordance with Section 1810.2.2 must be designed in accordance to the minimum unbraced length as defined in the code. The minimum unbraced length is defined in the second paragraph of Section 1810.2.1.

The first five (5'-0) feet of a pier or pile placed in a stiff soil should be considered unbraced unless the pier or pile is defined as laterally braced in all directions by the IBC in Section 1810.2.2. In a soft soil, the first ten (10'-0) feet is considered unbraced. Most geotechnical engineers classify a soft soil as having an N-value of 4 or less and a stiff soil as having an N-value of 5 or greater. Section 3.11.2.1 of AC308 has also adopted this classification for stiff and soft soils. Section 3.11.2.1 also defines fluid soils as any soil with a Standard Penetration Test blow count (N-value) of zero [weight of hammer (WOH) or weight of rods (WOR)].

Most remedial underpinning performed on existing structures will be defined as an unbraced deep foundation element. A side load bracket or haunch used to transfer structural loads to a pile or pier will not meet the stability or bracing requirements of Section 1810.2.2 of the IBC unless an engineered means of bracing the pile is provided.

Figure 4.3 illustrates a remedial repair bracket installed on an existing foundation. Since an engineered means of bracing is not typically provided with remedial repair brackets, the pile must be designed for the minimum unbraced length as described in Section 1810.2.1 of the IBC. The code is implying that the passive earth pressure distribution along the pile shaft is similar to the lateral soil load on a retaining or basement wall. The soil will not provide sufficient lateral support to the pile shaft to prevent buckling of the shaft until the minimum embedment prescribed by the code has been met. At the minimum embedment depth, the pile shaft can be considered fixed for structural analysis.

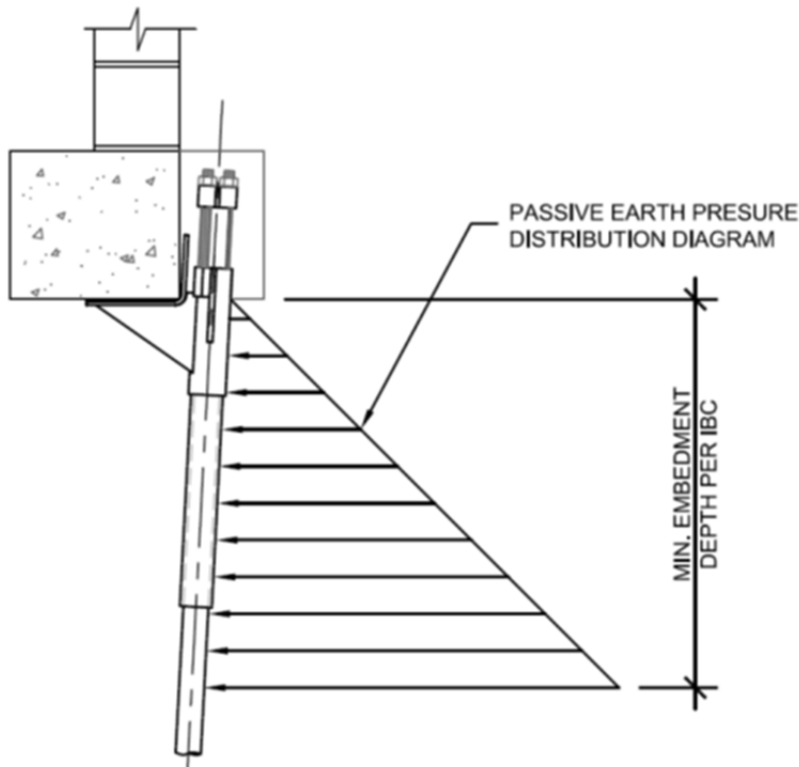

Figure 4.3: Typical Remedial Repair Bracket Installation

As can be seen in Figure 4.3, the pile must also be designed to resist the eccentricity of the bracket. Figure 4.1 shows the moment created from the bracket eccentricity is taken as the distance from the vertical face of the

footing or bearing wall to the center of the pile. Calculating capacities of remedial repair brackets can be extremely difficult when taking the interactions of bearing seats, gussets, sleeves, welds and friction into account. Therefore, ICC Evaluation Services included a full scale test procedure in AC358 for remedial repair brackets as shown in Figure 4.4. The test setup complies with the intent of Section 1810.2.1 of the IBC by including the minimum 5-foot unbraced length of the pile shaft. It also provides true bracket capacities that would be obtained in the field as test procedure measures the capacity of

the bracket and pile components as an interactive system. Ram Jack has several brackets and their capacities that are recognized by ICC in Table 1 of ESR-1854. A copy of ESR-1854 can be found in appendix B.

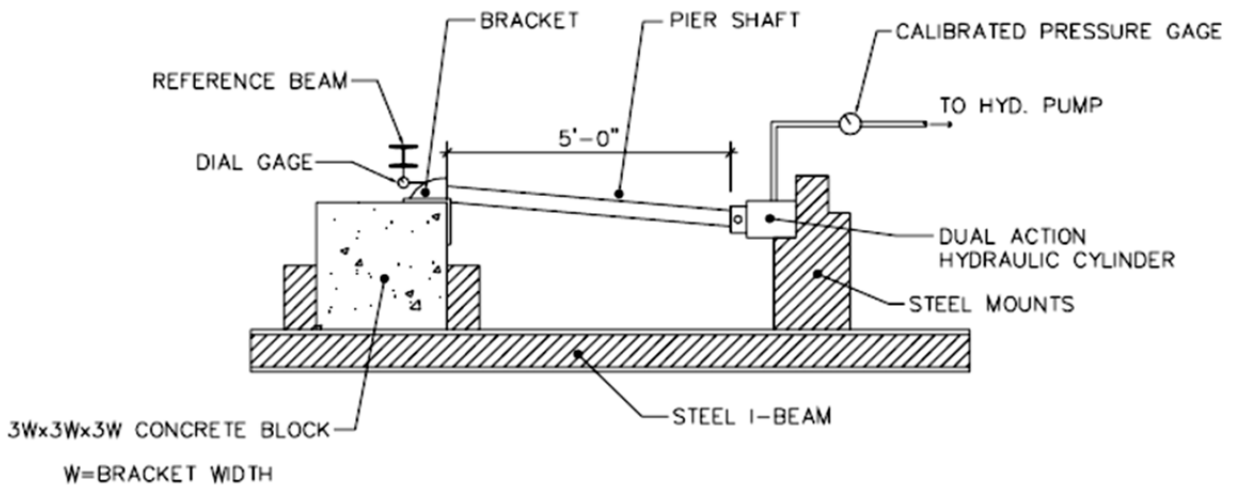

Figure 4.4: Typical AC358 Remedial Repair (Side Load) Bracket Test Setup

1810.2.2 Stability. *Deep foundation elements shall be braced to provide lateral stability in all directions. Three or more elements connected to a rigid cap shall be considered braced, provided that the elements are located in radial directions from the centroid of the group not less than 60 degrees (1 rad) apart. A two-element group in a rigid cap shall be considered to be braced along the axis connecting the two elements. Methods used to brace deep foundation elements shall be subject to the approval of the building official.*

Deep foundation elements supporting walls shall be placed alternately in lines spaced at least 1 foot (305 mm) apart located symmetrically under the center of gravity of the wall load carried, unless effective measures are taken to provide for eccentricity and lateral forces, or the foundation elements are adequately braced to provide for lateral stability.

Exceptions:

1. *Isolated cast-in-place deep foundations elements without lateral bracing shall be permitted where the least horizontal dimension is no less than 2 feet (610 mm), adequate lateral support in accordance with Section 1810.2.1 is provided for the entire height and the height does not exceed 12 times the least horizontal dimension.*
2. *A single row of deep foundations without lateral bracing is permitted for one- and two-family dwellings and lightweight construction not exceeding two stories above grade plane or 35 feet (10 668 mm) in building height, provided the centers of the elements are*

located within the width of the supported wall.

As previously stated, Section 1810.2.2 defines a fully braced deep foundation element. In previous International Building Codes, the code always preceded the definition of an unbraced foundation element with that of a braced foundation element which seems a more logical order. The reason for the change in the 2009 and 2012 IBC is unclear.

For stability of the structure, Section 1810.2.2 requires all deep foundation elements to be braced to provide lateral stability in all directions. This section goes on to provide four (4) prescriptive conditions where piles can be considered laterally braced:

1. Three or more piles connected by a rigid cap, provided the piles are located in radial directions from the centroid of the group not less than 60 degrees apart. (Figure 4.5a)
2. A two pile group connected by a rigid cap is braced along the axis connecting the two piles. A wall or grade beam would have to be connected perpendicular to the cap in order to provide bracing in the opposing direction. (Figure 4.5b)
3. Piles supporting walls shall be staggered on each side of the wall at least 1-foot apart and located symmetrically under the center of gravity of the wall provided measures are taken to provide for eccentricity, lateral forces or piles to be adequately braced to provide lateral stability. (Figure 4.5c)

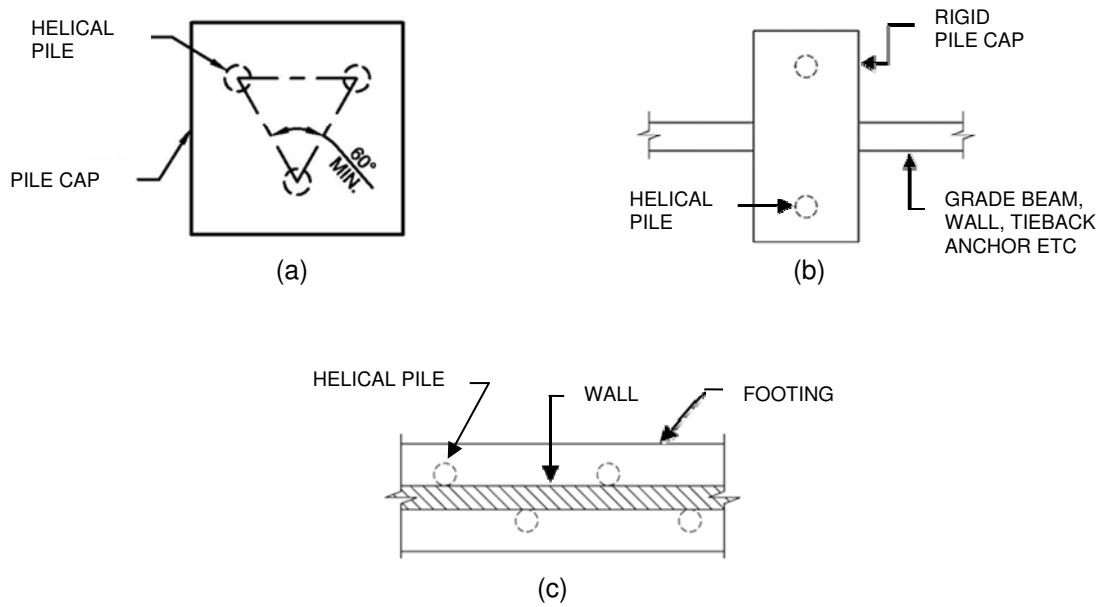

Figure 4.5: Prescriptive Lateral Bracing Requirements per Section 1810.2.2 of IBC

4. A single row of piles without lateral bracing is permitted for one- and two-family dwellings not exceeding two stories or 35 feet, provided the centers of the piles are located within the width of the supported wall.

If none of the above four requirements are met, the pile is considered unbraced by default. Therefore, an engineered means

must be used to brace the structure and piles if the piles cannot resist the buckling stresses due to the minimum unbraced length defined in Section 1810.2.1. There are several different means of providing lateral bracing to a pile. The most common methods are using helical tiebacks, a strong-back (waler) connected to several pile shafts or diagonal bracing to an adjacent pile. (Reference Figure 4.6)



(a)



(b)

Figure 4.6: Lateral Bracing – (a) Helical Tiebacks and (b) Diagonal Bracing

1810.2.5 Group Effects. *The analysis shall include group effects on lateral behavior where the center-to-center spacing of deep foundation elements in the direction of lateral force is less than eight times the least horizontal dimension of the element. The analysis shall include group effects on axial behavior where the center-to-center spacing of the deep foundation elements is less than three times the least horizontal dimension of an element.*

Due to the slenderness of the central shaft of a helical pile, the group effect on the minimum horizontal spacing is much larger than the code allows. For axial loaded helical piles, Section 6.7 of AC308 requires that a group efficiency analysis must be performed on helical piles with a center-to-center spacing less than three times the largest helical plate diameter of the pile. For example, a helical pile with an 8"-10"-12" helical plate configuration on the lead section must not be spaced closer than three feet (3'-0") center-to-center without performing a group efficiency analysis.

It's important to note that it isn't the center-to-center spacing of the piles that is required to be spaced 3D apart; it's the center-to-

center spacing of the largest helical plates on the piles. In most cases, piles can be battered slightly in opposing directions to obtain the helical plate spacing to avoid group effects. (Reference Figure 4.7)

SECTION 1810.3 – DESIGN AND DETAILING

1810.3.1.5 Helical Piles. *Helical piles shall be designed and manufactured in accordance with accepted engineering practice to resist all stresses induced by installation into the ground and service loads.*

Please reference Tables A-1 through A-6 in Appendix A for mechanical strengths, section properties and torque ratings of all the Ram Jack helical standard piles and allowable capacities of common brackets. This information as well as AutoCAD drawings and specifications are available online by clicking on the engineering portal at www.ramjack.com.

1810.3.2.6 Allowable Stresses. *The allowable stresses for materials used in deep foundation elements shall not exceed those specified in Table 1810.3.2.6.*

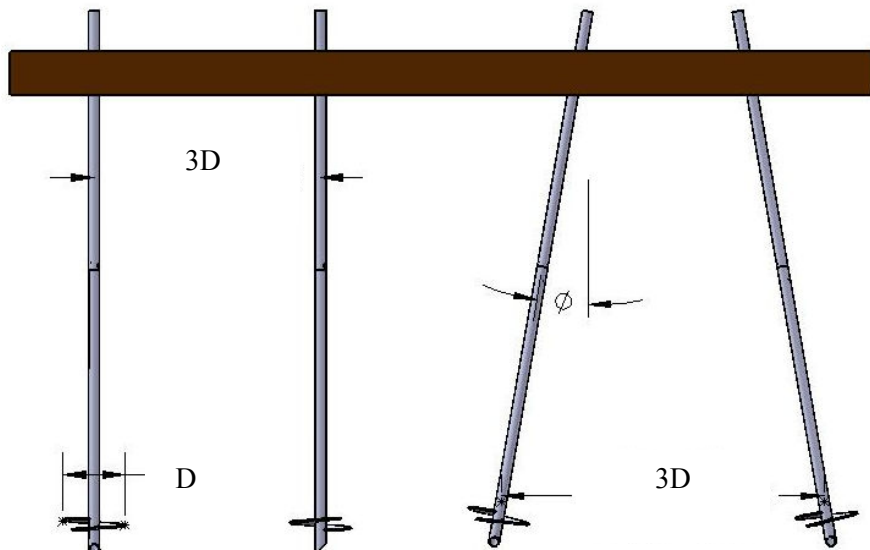

Figure 4.7: Minimum Helical Pile Spacing

Table 1810.3.2.6 Allowable Stress for Materials used in Deep Foundation Elements

MATERIAL TYPE AND CONDITION	MAXIMUM ALLOWABLE STRESS ^a
1. Structural steel in compression Helical piles	$0.6 F_y \leq 0.5 F_u$
2. Structural steel in tension Helical piles	$0.6 F_y \leq 0.5 F_u$

a. *F_y is the specified minimum yield stress of structural steel; F_u is the specified minimum tensile stress of structural steel.*

All of Ram Jack’s standard central pile shafts (2 3/8”, 2 7/8”, 3 1/2” and 4 1/2”) are a special manufactured ASTM-A500 Grade C steel and has a minimum yield strength of 65 ksi and a minimum tensile strength of 80 ksi. All the helical plates are manufactured from ASTM-A36 steel plate specifications but have a minimum yield strength of 50 ksi.

1810.3.3.1.9 Helical Piles. *The allowable axial design load, P_a, of helical piles shall be determined as follows:*

$$P_a = 0.5 P_u \quad \text{(EQUATION 18-4)}$$

where P_u is the least value of:

1. *Sum of the areas of the helical bearing plates times the ultimate bearing capacity of the soil or rock comprising the bearing stratum.*
2. *Ultimate capacity determined from well-documented correlations with installation torque.*
3. *Ultimate capacity determined from load tests.*
4. *Ultimate axial capacity of pile shaft.*

5. *Ultimate capacity of pile shaft couplings.*
6. *Sum of the ultimate axial capacity of helical bearing plates affixed to pile.*

An explanation and summary of each of the six design criteria required per the IBC for helical pile design have been listed below to better explain the design process and intent of the code.

Item 1 is in reference to the Individual Bearing Method. This method was discussed previously in Section 3.6.2 of Chapter 3. The method requires prior knowledge of the soil properties at the site via a soils report or boring logs. Please note that most soil reports only report the allowable bearing capacity of a soil or stratum. This allowable capacity normally has a safety factor of two or three applied. Applying another factor of safety of two per the IBC would be extremely conservative.

Typical helical plate sizes are 8”, 10”, 12”, 14” and 16” in diameter. The maximum number of helical plates placed on a single pile is normally set at six (6). The central area of the shaft is typically omitted from the effective area of the helical plate when using the Individual Bearing Method.

Item 2 is in reference to the Torque Correlation Method. The Torque Correlation Method is an empirical method that distinguishes the relationship between helical pile capacity and installation torque and has been widely used since the 1960's. The process of a helical plate shearing through the soil or weathered bedrock in a circular motion is equivalent to a plate penetrometer test. The method gained notoriety based on the study performed by Hoyt and Clemence (1989). Their study analyzed 91 helical pile load tests at 24 different sites within various soil types ranging from sand, silt and clay soils. They demonstrated the direct correlation of the installation torque of a helical pile to its ultimate capacity in compression or tension. The common denominator discovered from the study was a parameter referred to as the torque correlation factor, K_t .

The equation is:

$$P_u = K_t T$$

Where:

P_u = ultimate capacity of the helical pile or anchor [lb (kN)].

K_t = empirical torque factor of the central shaft of the pile [ft-1 (m-1)].

T is the final installation torque [ft-lb (m-kN)].

It's important to point out that the tests analyzed by Hoyt and Clemence (1989) were in tension. It was shown in subsequent studies that the tension capacity of helical piles was 16 to 33 percent less than the measured compression capacity. The difference is attributed to the fact that the lead helical plate is bearing on relatively

undisturbed soil in compression applications. In tension applications, the leading and trailing helical plates are bearing on soil affected by the installation of the helical plates. It has become common practice to use the same torque correlation factor for a helical pile of the same size for tension and compression and ignore the slight increase in compression capacity. This creates a more conservative compression capacity for helical piles when compared to the Individual Bearing Method. Also unlike the Individual Bearing Method, the number of helical plates on a pile is completely independent of the piles capacity based on the Torque Correlation Method. Please reference Section 3.6.3 of Chapter 3 of this manual for additional information on the Torque Correlation Method.

Ram Jack uses four (4) standard central pile shaft diameters. The recommended default torque correlation factor, K_t , for each diameter is listed in Table 4.1.

Item 3 is in reference to IBC approved load tests. The approved compression load test is ASTM D 1143 Standard Test Methods for Deep Foundations Under Axial Compressive Load. The approved tension load test is ASTM D 3689 Standard Test Methods for Deep Foundations Under Axial Tensile Load. Please reference Sections 3.6.4 through 3.3.4.3 in Chapter 3 of this manual for a summary of the test procedures

There are three basic reasons to load test a helical pile:

1. When a project requires a more aggressive design approach. Please note that the default K_t values shown in Figure 1 are conservative and are based on numerous load test analysis. A load test would provide the ultimate load capacity and

Table 4.1: Default Torque Correlation Factors and Torsional Ratings^a

Pile Diameter	2 3/8”	2 7/8”	3 1/2”	4 1/2”
K_t (default)	10	9	7	6
Torque Rating, T (ft-lb)	4,000	8,000	14,000	23,000
Ultimate Capacity, P_u (lb)	40,000	72,000	98,000	138,000

- a. *The structural capacity of the pile must be checked per item 4 of Section 1810.3.3.1.9 to ensure it does not govern the limit state of the pile. Ram Jack pile materials are manufactured from specialty materials. Please reference Table A-5 in appendix A for applicable mechanical strengths and section properties.*

actual K_t value for the specific project site.

2. Where the design compressive loads are greater than those determined using the allowable stresses specified in Section 1810.3.2.6.
3. Where the design load for any deep foundation element is in doubt.

Item 4 is in reference to the structural axial capacity of the central pile shaft. The structural calculations should be performed in accordance with methods prescribed in the *Manual of Steel Construction* (AISC) and the *International Building Code* (IBC). The structural analysis should take into account any applicable unbraced length per Section 1802.1, pile eccentricities, as well as flexural and bending stresses. The pile eccentricity for helical piles used with remedial brackets is normally measured from the vertical face of the wall load or the concrete footer for a column. Ram Jack pile materials are manufactured from specialty materials. Please reference Table A-5 of appendix A for applicable mechanical strengths and section properties. Allowable loads for common helical piles and brackets can

also be found in Tables A-1 through A-3 of appendix A.

Item 5 Ram Jack’s helical pile couplings are designed to exceed the structural capacity of the central pile shaft based on the Torque Correlation Method. Please reference Table 4.1 for maximum allowable torque ratings of Ram Jack’s standard pile shafts.

Item 6 is in reference to the structural capacity of the helical plate welded to the central shaft of the pile. Table A-6 in the appendix A provides a complete list of strength ratings for each helical plate Ram Jack manufactures based on the plates diameter, thickness and central shaft it is attached to.

1810.3.3.2 Allowable Lateral Load. *Where required by the design, the lateral load capacity of a single deep foundation element or a group thereof shall be determined by an approved method of analysis or by lateral load tests to at least twice the proposed design working load. The resulting allowable load shall not be more than one-half of the load that produces a gross lateral movement of 1 inch (25 mm) at the lower of the top of the foundation element and the ground surface, unless it can be shown that*

the predicted lateral movement shall cause neither harmful distortion of, nor instability in, the structure, nor cause any element to be loaded beyond its capacity.

Helical piles are slender deep foundation elements that typically range from 2 3/8" to 4 1/2" in diameter. When helical piles are subjected to lateral loads, a lateral load analysis should be performed using a program such as LPILE or equivalent or field tested on the project site as described in Section 1810.3.3.2. When performing an LPILE analysis the geotechnical engineer should provide the soil parameters (c , ϕ , γ and k_s) which are required to be entered into the software.

When the lateral loads are large there are several methods available to resist the forces. The moment of inertia (stiffness) of the upper portion of the pile can be increased; a pile cap can be used to create a couple moment; the piles can be battered or a helical tieback anchor can be connected to the foundation system or vertical helical pile. Please reference Section 3.8 in Chapter 3 for a list of common methods used to increase the lateral capacity of helical piles.

1810.3.5.3 Steel. *Steel deep foundation elements shall satisfy the requirements of this section.*

1810.3.5.3.3 Helical Piles. *Dimensions of the central shaft and the number, size and thickness of the helical bearing plates shall be sufficient to support the design loads.*

Reference appendix Tables A-1 and A-6 in appendix A for Ram Jack's standard central shaft and helical plate sizes as well as strength and section properties.

1810.3.11 Pile Caps. *Pile caps shall be of reinforced concrete, and shall include all*

elements to which vertical deep foundation elements are connected, including grade beams and mats. The soil immediately below the pile cap shall not be considered as carrying any vertical load. The tops of the vertical deep foundation elements shall be embedded not less than 3 inches (76 mm) into pile caps and the caps shall extend at least 4 inches (102 mm) beyond the edges of the elements. The tops of the elements shall be cut or chipped back to sound material before capping.

Section 1810.3.11 applies to all deep foundation elements. The minimum embedment depth of three (3") inches is intended for compression loads only. It's important to point out that where a helical pile is required to resist tension loads or a combination of tension and compression, the embedment depth of the helical pile may need to be increased or applicable nelson studs, weldable deformed bars, concrete anchor bolts or headed studs will be needed to provide a tension connection between the concrete and helical pile. If the depth of the concrete pile cap, grade beam or mat foundation, the embedment depth of the helical pile could be analyzed as a single headed stud per ACI 318 appendix D.

Tension load capacities for Ram Jack's standard new construction brackets for 2 7/8" and 3 1/2" diameter piles can be found in Table 3B of ESR-1854. A copy of ESR-1854 has been included in appendix B. Table 3B provides ICC rated tension capacities for the 4075, 4079 and 4076 new construction brackets based on varying embedment depths. The tension capacities are based on localized limit states such as mechanical strength of steel components, concrete bearing and punching shear capacity.

1810.4.11 Helical Piles. *Helical piles shall be installed to the specified embedment depth and torsional resistance criteria as determined by a registered design professional. The torque applied during installation shall not exceed the maximum allowable installation torque of the helical pile.*

The torque ratings of Ram Jack’s helical piles can be found in Table 4.1.

1810.4.12 Special Inspection. *Special inspections in accordance with Sections 1704.8 and 1704.9 shall be provided for driven and cast-in-place deep foundation elements, respectively. Special inspections in accordance with Section 1704.10 shall be provided for helical piles.*

1704.10 Helical Pile Foundations. *Special inspections shall be performed continuously during installation of helical pile foundations. The information recorded shall include installation equipment used, pile dimensions, tip elevations, final depth, final installation torque and other pertinent installation data as required by the registered design professional in responsible charge. The approved geotechnical report and the construction documents prepared by the registered design professional shall be used to determine compliance.*

Per Section 1704.10 item 3 under exceptions, “*Unless otherwise required by the building official, special inspections are not required for Group U occupancies that are accessory to a residential occupancy including, but not limited to, those listed in Section 312.1.*”

SECTION 312 UTILITY AND MISCELLANEOUS GROUP U

312.1 General. *Buildings and structures of an accessory character and miscellaneous*

structures not classified in any specific occupancy shall be constructed, equipped and maintained to conform to the requirements of this code commensurate with the fire and life hazard incidental to their occupancy. Group U shall include, but not be limited to, the following:

*Agriculture buildings
Aircraft hangers, accessory to a one- or two-family residence (see Section 412.5)
Barns
Carports
Fences more than 6 feet (1829 mm) high
Grain silos, accessory to a residential occupancy
Greenhouses
Livestock shelters
Private garages
Retaining walls
Sheds
Stables
Tanks
Towers*

Please feel free to contact Ram Jack’s Engineering Department should you have any questions or need technical assistance when designing a deep foundation system with helical piles.