

LEAD SECTIONS - PARTS LIST

PART NUMBER	DIM 'A'	DIM 'B'	DIM 'C'
E35300601012L	60"	10"	12"
E3530084810L	84"	8"	10"
E35300841012L	84"	10"	12"
E35300841214L	84"	12"	14"
E35300841416L	84"	14"	16"
E35300120810L	120"	8"	10"
E353001201012L	120"	10"	12"
E353001201214L	120"	12"	14"
E3530036E	36"		
E3530060E	60"		
E3530084E	84"		
E35300120E	120"		
E353006012E	60"	12"	
E353006014E	60"	14"	
E353008414E	84"	14"	
E35300841414E	84"	14"	14"
E3530012014E	120"	14"	
E353001201414E	120"	14"	14"

GENERAL NOTES

1. SHAFT MATERIAL- 3 1/2" OD ASTM A500 GRADE C
Fy= 50 KSI, Ft= 62 KSI.
2. FINISH HOT DIPPED GALV. PER ASTM A 123/153.
3. ALL WELDING TO BE PERFORMED BY QUALIFIED WELDER TO AWS D1.1.
4. TORQUE STRENGTH RATING OF 15,500 FT-LBS.
5. ULTIMATE CAPACITY OF UNIT IS 108.5 KIPS.
6. HELIX SPACING SHALL BE 3X TIMES THE DIAMETER FROM THE LOWEST HELIX ACCORDANCE WITH ICC-ES AC358.
7. STEEL HELIX MATERIAL TO CONFORM TO ASTM A572, 50 KSI.
8. COUPLING BOLTS: 5 1/2" X 3/4" ASE J429 GRADE 5.
9. ALL MATERIAL IS MANUFACTURED IN U.S.A.

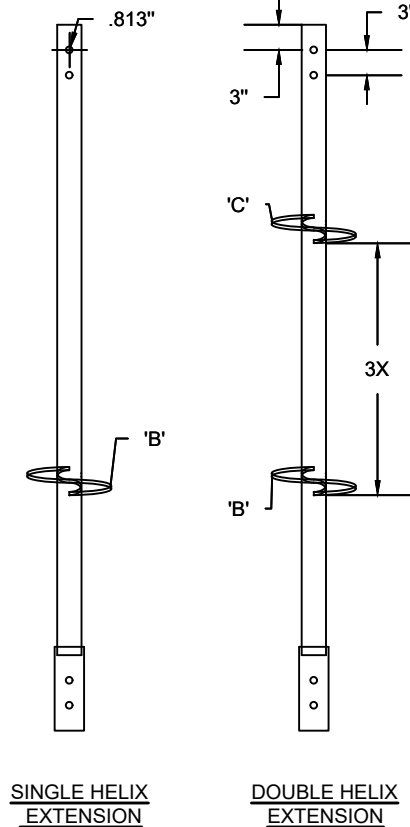
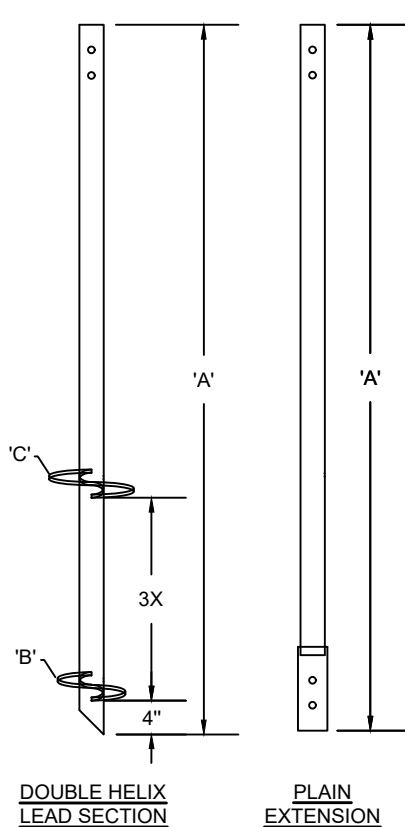
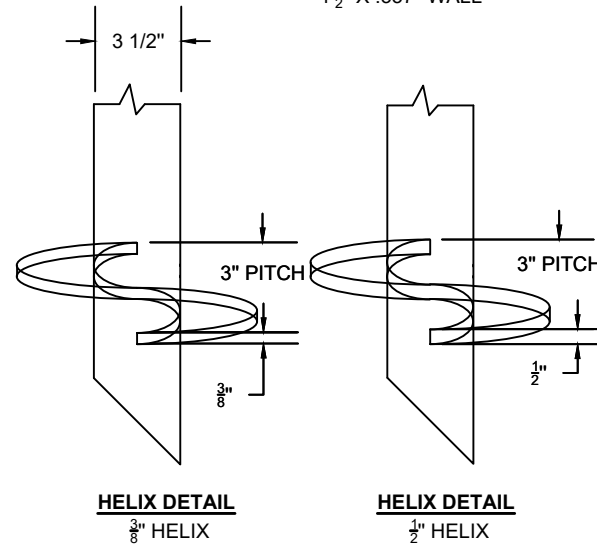
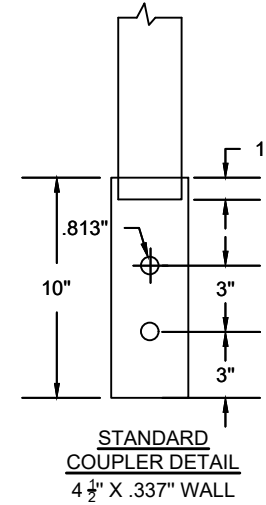

PROPRIETARY AND CONFIDENTIAL
THE INFORMATION CONTAINED IN THE DRAWING IS THE SOLE PROPERTY OF EMPIRE PIERS. ANY REPRODUCTION IN PART OR AS A WHOLE WITHOUT THE WRITTEN PERMISSION OF EMPIRE PIERS IS PROHIBITED.



DRAWN	DATE
Luke Brown	11/18/2022
CHECKED	DATE
APPROVED	DATE
MFG	DATE
Empire Piers	11/18/2022
SCALE	SHEET
NTS	1 of 1

EMPIRE PIERS
2656 EAST HWY 47
WINFIELD, MO 63389
(636) 668-8066

TITLE
3 1/2" OD x .300" WALL
DOUBLE LEADS &
EXTENSIONS

PART NUMBER
E35300XXXX-01