

LEAD SECTIONS - PARTS LIST				
PART NUMBER	DIM 'A'	DIM 'B'	DIM 'C'	DIM 'D'
E2378481012L	84"	8"	10"	12"
E23784101214L	84"	10"	12"	14"
E23712081012L	120"	8"	10"	12"
E237120101214L	120"	10"	12"	14"
E23736E		36"		
E23760E		60"		
E23784E		84"		
E237120E		120"		

**GENERAL NOTES**

1. SHAFT MATERIAL -  $\phi$  2 3/8" OD x 0.190" WALL J-55 API SGT CERTIFIED PIPE. F<sub>y</sub> = 55 KSI, F<sub>t</sub> = 75 KSI.
2. FINISH HOT DIPPED GALV. PER ASTM A 123/153.
3. ALL WELDING TO BE PERFORM BY QUALIFIED WELDER TO AWS D1.1
4. TORQUE STRENGTH RATING OF 4,500 FT-LBS
5. ULTIMATE CAPACITY OF UNIT IS 45 KIPS
6. HELIX SPACING SHALL BE 3 X THE DIAMETER FROM THE LOWEST HELIX IN ACCORDANCE WITH ICC-ES AC308.
7. STEEL HELIX MATERIAL TO CONFORM TO ASTM A572, 50 KSI. HELIX GEOMETRY IN ACCORDANCE WITH ICC-ES AC358.
8. COUPLING BOLTS: 3 1/2" x 7/8" A5E 1429 GRADE 5 BOLT SHEAR = 85 KSI, YIELD STRENGTH = 92 KSI, TENSILE STRENGTH = 120 KSI
9. ALL MATERIAL IS MANUFACTURED IN U.S.

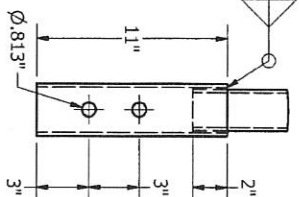
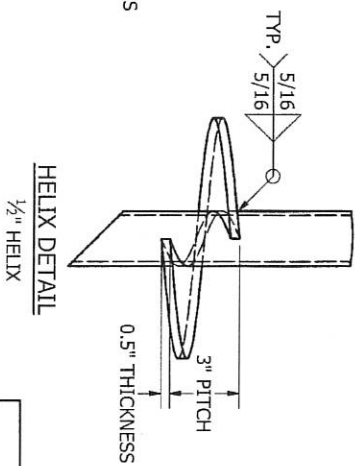
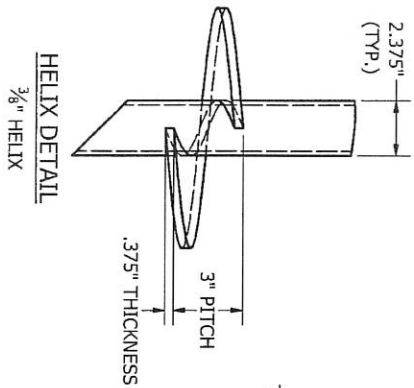
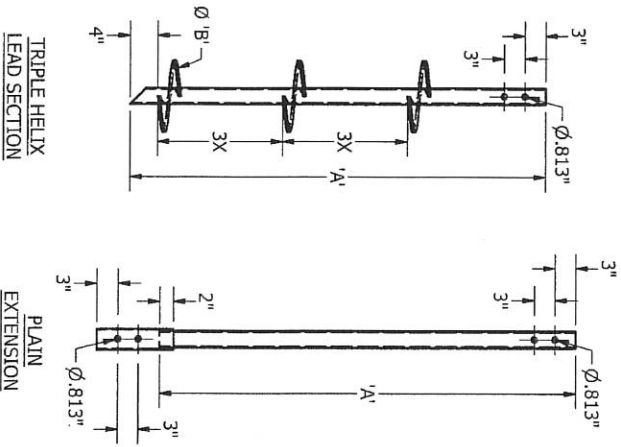

STANDARD  
COUPLER DETAIL  
 $\phi$  2 3/8" x 0.203" WALL

PROPRIETARY AND CONFIDENTIAL  
THE INFORMATION CONTAINED IN THE  
DRAWING IS THE SOLE PROPERTY OF EMPIRE  
PIERS. ANY REPRODUCTION IN PART OR AS A  
WHOLE WITHOUT THE WRITTEN PERMISSION  
OF EMPIRE PIERS IS PROHIBITED.



DRAWN	John Stanek	10/3/2016	<b>EMPIRE PIERS</b> 2656 EAST HIGHWAY 47 WINFIELD, MO 63389 (636) 668-8066
CHECKED	Luke Brown	10/3/2016	
APPROVED	Greg Pyle	10/3/2016	
DATE	10/3/2016		
SCALE	NTS	DWG SIZE	B
DWG NO.	E2375X03	SHEET	1 of 1

2 3/8 X .190 Pipe

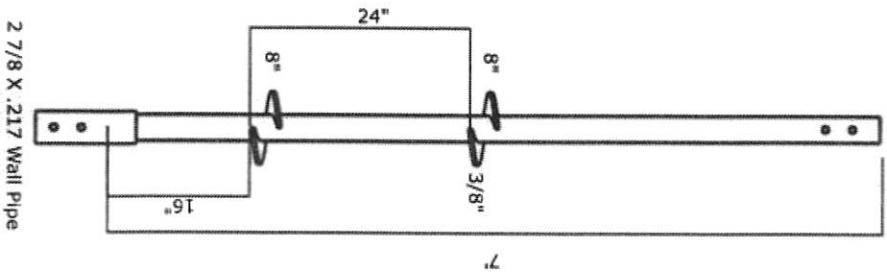

DRAWN BY:	Tim Gross	Date:	11/3/2020	 Empire Piers 2656 EAST HIGHWAY 47 WINFIELD, MO 63389 (636) 668-8066	
CHECKED BY:	Tim Gross	Date:	11/3/2020		
APPROVED BY:		Date:			
MANUFACTURED BY:					
SCALE:	NTS	DWG SIZE:	A4	Part #	DWG #